

Features

- DC input: 80 - 800 V
- AC input: 3-phase, 47 - 400 Hz
- DC output: 24 / ... / 400 V
- Continuous short circuit protection
- Overvoltage protection
- Thermal shutdown with auto restart
- Industrial grade components
- High efficiency through ZVS topology
- High power density
- Compact and robust design

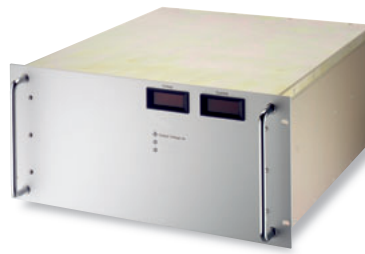

front view



rear view

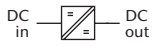

DC / DC Converters

▶ 7.5 KW			▶ 15 KW					
Input VDC							Output VDC	
80–160 VDC	Output Amps	160–320 VDC	320–380 ¹⁾ VDC	320–640 VDC	450–800 VDC	Output Amps	Adj.	Range
CW 5554	288	CW 5574	CW 5584 Z	CW 5574 G	CW 5574 K	350	24	23– 26
CW 5555	250	CW 5575	CW 5585 Z	CW 5575 G	CW 5575 K	350	28	26– 30
CW 5559	136	CW 5579	CW 5589 Z	CW 5579 G	CW 5579 K	273	48	45– 55
CW 5556	110	CW 5576	CW 5586 Z	CW 5576 G	CW 5576 K	220	60	58– 68
CW 5557	58	CW 5577	CW 5587 Z	CW 5577 G	CW 5577 K	116	110	100– 130
CW 5557 J	38	CW 5577 J	CW 5587 ZJ	CW 5577 GJ	CW 5577 KJ	75	200	190– 200
CW 5558	30	CW 5578	CW 5588 Z	CW 5578 G	CW 5578 K	60	220	200– 250
CW 5558 J	19	CW 5578 J	CW 5588 ZJ	CW 5578 GJ	CW 5578 KJ	38	400	380– 400



AC / DC Converters

▶ 15 KW					
Input VAC, 3-Phase				Output VDC	
3x200 ^{+15%} _{-20%}	3x400 ^{+15%} _{-20%}	3x480 ^{+10%} _{-15%}	Output Amps	Adj.	Range
CW 5564 V	CW 5584 V	CW 5594 V	350	24	23– 26
CW 5565 V	CW 5585 V	CW 5595 V	350	28	26– 30
CW 5569 V	CW 5589 V	CW 5599 V	273	48	45– 55
CW 5566 V	CW 5586 V	CW 5596 V	220	60	58– 68
CW 5567 V	CW 5587 V	CW 5597 V	116	110	100– 130
CW 5567 VJ	CW 5587 VJ	CW 5597 VJ	75	200	190– 200
CW 5568 V	CW 5588 V	CW 5598 V	60	220	200– 250
CW 5568 VJ	CW 5588 VJ	CW 5598 VJ	38	400	380– 400

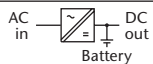

Battery Chargers

▶ 15 KW					
Input VAC, 3-Phase				Output VDC	
3x200 ^{+15%} _{-20%}	3x400 ^{+15%} _{-20%}	3x480 ^{+10%} _{-15%}	Output Amps	Nom. Battery Voltage	Range
BW 5562 V	BW 5582 V	BW 5592 V	328	24	24– 32
BW 5564 V	BW 5584 V	BW 5594 V	234	48	48– 64
BW 5566 V	BW 5586 V	BW 5596 V	188	60	60– 80
BW 5567 V	BW 5587 V	BW 5597 V	104	110	110– 145
BW 5568 V	BW 5588 V	BW 5598 V	52	220	220– 290

Assistance in table use:

- 1 Select the column for input voltage range.
- 2 Select the row for the appropriate output voltage.
- 3 The intersection of both results in the module required.

For example:

- 1 input voltage = 3 x 400 VAC
- 2 output voltage = 220 VDC @ 60 A
- 3 results in a CW 5588 V module.

¹⁾ input supply from PFC also suitable

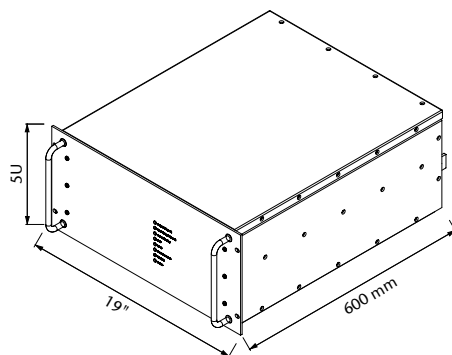

19" Plug-in module / approx. 58 kg

Specifications

Input

Voltage range narrowing of input voltage range optimizes the efficiency (pls. specify), unit switches off at under- and overvoltage

No-load input power. 30 W typical

Switch-on time < 1 s typical

Hold-up time AC input: 5 ms typical

Immunity

- ESD acc. to DIN / EN 61000-4-2 level 3

- Fast transients acc. to DIN / EN 61000-4-4 level 3

- Surges acc. to DIN / EN 61000-4-5 level 3

Output

Line regulation ($\pm 10\%$) 0.1 %

Load regulation (10-90 %) 0.2 %

Load transient (10-90-10 %) 6 % typical

Response time to $\pm 1\%$ 10 ms typical

Turn-on rise time Soft-start, 300 ms typical

Ripple $\leq 1\%$

Overload protection current limited to 105 - 110 % of I_{nom}

Overvoltage protection OVP switches off module with automatic return to operation, after 5 seconds, the unit will remain latched off

Remote sense standard for CW series up to 150 V output, up to 10 % of U_{nom} for output < 60 VDC, up to 6 V for output > 60 VDC

General

Efficiency 80 - 95 %

Operating temperature -20 to $+75\text{ }^{\circ}\text{C}$

Load derating 2.5 % / $^{\circ}\text{C}$ from $+55\text{ }^{\circ}\text{C}$

Storage temperature -40 to $+85\text{ }^{\circ}\text{C}$

Humidity up to 95 % RH, non-condensing

Cooling with water

Temperature coefficient 0.02 % / $^{\circ}\text{C}$ typical

Safety / Construction acc. to DIN / EN 60950-1: 2003

Protection category IP 20, others or NEMA upon request

EMI acc. to EN 55022, class A, optionally class B

MTBF approx. 70,000 h @ $40\text{ }^{\circ}\text{C}$

acc. to MIL - HDBK - 217 E (notice 1)

Connector terminals / bolts / bars

Marking CE

Options (details see page xx)

Input

- Inrush current limiting
- Reverse polarity protection for DC input

Output

- Parallel operation
- Redundant operation
- Inhibit (remote on / off)
- Reducing of current limiting at high ambient temperature

Signals

via open collector or relay contacts

- Power ok (input)
- DC ok (output)
- Sys-reset

Programming

- Output voltage or current via
 - potentiometer
 - analog signal
 - interface RS232 or IEEE488

Battery charger

- Temperature compensated charging voltage
- Automatic / manual selection of charging characteristic

Monitoring

- Input / output voltage or current via
 - analog signal
 - interface RS232 or IEEE488

Mechanics / environment:

- Digital V- and A-meter (see photo)
- Tropical protection
- Extended temperature range to $-40\text{ }^{\circ}\text{C}$