

DC-DC CONVERTER ACR 45

RAILWAY CONVERTER.

FOR PCB MOUNTING



HIGHLIGHTS

- + Output Power up to 45 Watts*
- + Efficiency up to 89%
- + High Power Density
- + Wide Input Range
- + Wide Temperature Range
- + RoHS Compliant
- + According to EN 50155

INPUT

Input Voltage Nominal	12/24 VDC, 24 VDC (other inputs on request)
Disabled Input Current <	10 mA

OUTPUT

Output Voltage	5V / 12V / 15V / 24V
Initial Set Accuracy	< ± 1%
Minimum Load	No minimum load
Line Regulation	< ± 0,5%
Load Regulation <	1% (10% - 100% Load)
Ripple & Noise <	1% pk-pk, 20 MHz bandwidth
Start Time <	100 ms
Transient Response	< ± 3% (25% / 75% Load Step) Recovery Time < 500 us
Max. Output Capacitance	500uF x I _{out max}
Temperature Coefficient	0.02%/°C

FEATURES

Sync	The switching frequency can be synchronized to -5% (-10%, no trimming to positive direction possible) and +10% of the nominal frequency. TTL-Level.
Enable	Pulled to low (<0,8V ref. to -Vin) disables the converter. Open pin enables the converter.
Thermal Warning	An open-collector output pulls to -Vin when the temperature of the baseplate reaches 95 °C
Sense + / -	Remote sense to compensate for lead drops of the output line up to 0,5V
Trim	A resistor-programmable input to trim the output voltage in the range of +10% / - 20%
Share	Up to 3 converters can be connected in parallel sharing within < 10%

* Derating without additional cooling > +40 °C: 2,22%/°C
Derating with heatsink 4,3 KW > +70 °C: 3,82%/°C
Also with heatsink, ensure that baseplate not exceed 100°C

** In built-in condition our devices may show different EMC properties

PROTECTION

Over Voltage Protection (OVP)	110-120% V _{nom} , latched
Over Current Protection (OCP)	I _{out nom} > 105 %. The output switches off when V _{out nom} < 70% and restarts automatically latest after 0.5 s of elimination of the overload.
Over Temperature Protection (OTP)	Shutdown at +102 -105 °C baseplate with 5K hysteresis and auto recovery

GENERAL

Product Standard	EN 50155
Isolation	1500 VDC Input to Output 1000 VDC Input to baseplate 500 VDC Output to baseplate
Switching Frequency	440 kHz typ.
Dimensions [mm]	50,8 x 50,8 x 11,0
Weight	approx. 55g
MTBF	1.000.000 h at 25 °C

ENVIRONMENTAL

Operating Ambient Temp.	-40 °C to +85 °C*
Operating Case Temp.	-40 °C to +100 °C
Storage Temperature	-40 °C to +100 °C
Vibration / Shock / Bump	EN 61373:1999
Damp Heat	EN60068-2-30:2005

EMC & SAFETY

EMC Standard	EN 50121-3-2:2006
Conducted Emissions	EN 55011 2:2007+A2:2007.; Class A**
ESD Immunity	EN 61000-4-2:1995+A1:1998+A2:2001, level 3 (6kV/8kV), Criteria B
Radiated Immunity	EN 61000-4-3:2006, level X (20V/m), Criteria A
Burst	EN 61000-4-4:2004, level 3 (2kV), Criteria A
Surge	EN 61000-4-5:2006, level 1, ±0,5kV EN 50121-3-2:2006, line to line ±1kV, 42R, and line to case ±2kV, 42R, Criteria B
Conducted Immunity	EN 61000-4-6:1996+A1:2001, level 3 (10V), Criteria A
Safety Approvals	CE Mark LVD; EN 60950-1:2001

TECHNICAL DATA

For $T_{amb}=25^{\circ}\text{C}$, $V_{in\ nom}$, $I_{out\ nom}$, unless otherwise specified.

SPECIFICATION* Input 14,4 - 40 VDC

	TYPE	Unit	ACR45 24S05			ACR45 24S12			ACR45 24S15			ACR45 24S24		
			Min	Typ	Max	Min	Typ	Max	Min	Typ	Max	Min	Typ	Max
	ORDER NUMBER		72 21 08 0522 4			72 21 12 0522 8			72 21 15 0522 5			72 21 24 0522 4		
	CHARACTERISTIC	Unit	Min	Typ	Max	Min	Typ	Max	Min	Typ	Max	Min	Typ	Max
INPUT	Under Voltage Turn-on	V	14,4											
	Under Voltage Turn-off	V	< 14,0											
	Input Current @ full Load	A		1,65			2,14			2,14				2,10
	Input Current @ $V_{in} = 14,4\text{V}$	A		2,8			3,7			3,7				3,7
	Input Current @ no Load	mA		75			75			45				45
	External Fusing	A	6											
OUTPUT	Output Voltage	V		5,0			12,0			15,0			24,0	
	Output Power	W			35,0			45,6			45,0			45,6
	Efficiency	%		88			88			88			89	
	Output Current	A			7,0			3,8			3,0			1,9

SPECIFICATION* Input 9 - 36 VDC

	TYPE	Unit	ACR45 12/24S05			ACR45 12/24S12			ACR45 12/24S15			ACR45 12/24S24		
			Min	Typ	Max	Min	Typ	Max	Min	Typ	Max	Min	Typ	Max
	ORDER NUMBER		73 21 08 0322 2			73 21 12 0322 6			73 21 15 0322 3			73 21 24 0322 9		
	CHARACTERISTIC	Unit	Min <td>Typ <td>Max</td> <td>Min</td> <td>Typ</td> <td>Max</td> <td>Min</td> <td>Typ</td> <td>Max</td> <td>Min</td> <td>Typ</td> <td>Max</td> </td>	Typ <td>Max</td> <td>Min</td> <td>Typ</td> <td>Max</td> <td>Min</td> <td>Typ</td> <td>Max</td> <td>Min</td> <td>Typ</td> <td>Max</td>	Max	Min	Typ	Max	Min	Typ	Max	Min	Typ	Max
INPUT	Under Voltage Turn-on	V	10											
	Under Voltage Turn-off	V	< 9											
	Input Current @ full Load	A		1,6			2,05			2,05				2,07
	Input Current @ $V_{in} = 9\text{V}$	A		4,4			5,6			5,6				5,65
	Input Current @ no Load	mA		75			75			45				45
	External Fusing	A	8											
OUTPUT	Output Voltage	V		5,0			12,0			15,0			24,0	
	Output Power	W			33,0			42,0			42,0			43,2
	Efficiency	%		86			86			86			87	
	Output Current	A			6,6			3,5			2,7			1,8

* data for $V_{in\ nom} = 24\text{V}$

TECHNICAL DATA

For $T_{amb}=25^{\circ}\text{C}$, $V_{in\ nom}$, $I_{out\ nom}$, unless otherwise specified.

MECHANICAL DETAILS

- Dimensions are in mm
- Tolerance: $\pm 0.5\text{ mm}$

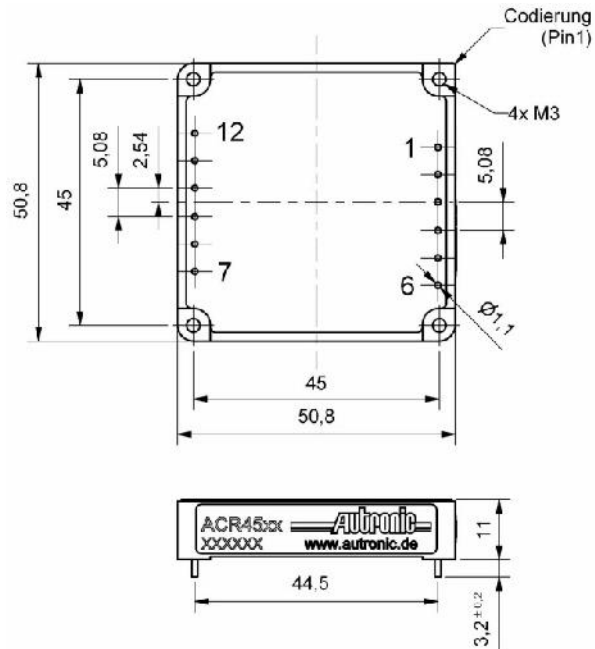

Pin - Material: Tin plated brass
 Case - Frame: Pocan B4235, 30GF, UL-V0, black
 Baseplate: Aluminum coated

PINNING

Pin	Function
1	Baseplate
2	SY
3	V_{in-}
4	V_{in+}
5	EN
6	TW
7	S+
8	V_{out+}
9	Trim
10	V_{out-}
11	S-
12	Share

BLOCK DIAGRAM

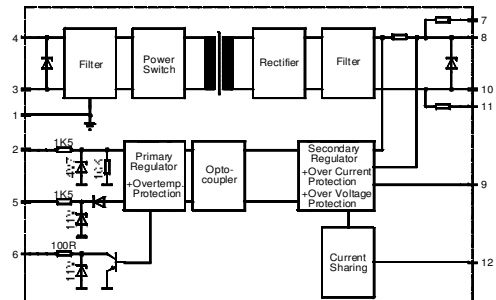

NOTES

Installation instructions:

The converters have to be installed according to the guidelines currently in force, like other open electronic component assemblies. Attention must be paid to sufficient ventilation, carry off heat, fastening and protection against accidental contact. The mounting surface must be flat and able to remove the thermal energy of the baseplate (baseplate temperature must not exceed $+100^{\circ}\text{C}$).

The pin 1, baseplate: (∇ / \oplus), has to be properly connected in order to assure operation.

External fusing:

High switching off capacity. For disconnecting from the preceding supply, sufficient current of the supply point to trigger the fuse in case of short-circuit has to be made sure.